



Technical Specifications  
**CNMV Corporate  
Actions**

## Index

1	PRODUCT DESCRIPTION .....	4
1.1	FILE AVAILABILITY.....	4
1.2	CLIENT SUPPORT .....	4
2	FORMAT AND DATA DELIVERY .....	6
2.1	FILE FORMAT .....	6
2.2	DATA FORMAT .....	6
2.2.1	Numeric Format.....	6
2.2.2	Date and Time Convention.....	6
2.2.3	Data Delivery .....	6
2.2.4	File Names .....	6
3	FILE DESCRIPTION .....	8
3.1	PRICESENSITIVE_ANNOUNCEMENT_YYYYMMDD.csv .....	8
3.2	EXCHANGE_NOTICES_YYYYMMDD.csv .....	9
3.3	RELEVANT INFORMATION. REGISTRATION DATA .....	11
3.4	INTERIM FINANCIAL INFORMATION. ....	11
3.5	AUDITS.....	13
3.6	VOTING RIGHTS AND FINANCIAL INSTRUMENTS.....	13
3.7	ISIN .....	14
3.8	MAB CORPORATE ACTIONS .....	14

4 ANNEX 1 .....	17
4.1 INTRODUCTION.....	17
4.2 FILE DESCRIPTION .....	17
4.3 REGISTER DESCRIPTION.....	18
4.3.1 RELEVANT INFORMATION .....	18
4.3.2 AUDITS.....	24
4.3.3 ISIN .....	25
4.3.4 VOTING RIGHTS AND FINANCIAL INSTRUMENTS.....	31
5 ANNEX 2. DEFINITION OF THE XML FILES SCHEMES .....	44
5.1 RELEVANT INFORMATION FILES .....	44
5.2 AUDIT FILES.....	47
5.3 VOTING RIGHTS AND FINANCIAL INSTRUMENTS FILES.....	48
5.4 ISIN FILES .....	57

# 1 Product Description

The product on CNMV corporate actions is made up of the following information files:

**PRICESENSITIVE\_ANNOUNCEMENT\_YYYYMMDD.csv.** Summary list of all the corporate actions of the day that affect all companies supervised by the CNMV (whether or not listed).

**EXCHANGE\_NOTICES\_YYYYMMDD.csv.** List of corporate actions in the day that affect (void or modify) preceding corporate actions.

**Relevant information. Registration Data.** File(s) with communication on relevant information made by the issuers and received by the CNMV the day in which the file is created.

**Interim Financial Information.** File(s) containing all the quarterly and/or semester reports filed with the CNMV by the companies that have securities admitted to trading in Regulated Markets the day the file is created.

**Audits.** File(s) containing registration data of the audits of the issuers received by the CNMV the day the file is created.

**Voting rights and financial instruments.** File(s) containing the following information: last position, at the date the file is created, of the listed companies concerning their treasury stock, voting rights and holdings of financial instruments that grant the right to acquire shares to directors, significant shareholders and executives.

**ISIN.** File containing the additions and withdrawals from the financial instruments database of the Spanish National Agency of Securities Codification.

**MAB CORPORATE ACTIONS.** Txt file that collects the corporate actions of the MAB companies, associated with said file links to the PDF files of the notice.

## 1.1 FILE AVAILABILITY

The information is available from 8:00 a.m. CET onwards and it is updated every 10 minutes, save the market messages and market notifications which will normally be available at 20:00 CET every trading of the TARGET calendar.

## 1.2 CLIENT SUPPORT

ADDRESS	EMAIL	TELEPHONE
Palacio de la Bolsa, Plaza de la Lealtad 1, 28014 - Madrid	marketdata@grupobme.es	+ 34 91 709 58 10

Users have at their disposal a client support service Monday to Friday from 09:00 to 18:30 CET. BME Market Data will keep the Client updated on any modification on the files, as well as on any technical improvements.

## 2 Format and Data Delivery

### 2.1 FILE FORMAT

BME MARKET DATA provides the data for this product in files with the following formats:

- Format TXT, CSV (“;” or “|” as field separator and “.” or “,” as decimal separator). This format is compatible with both databases and spreadsheets. Each field in the file will be separated from the following field by “;” and each line ends with the specific character of line end.
- Format XML (each field is included in a tag).

### 2.2 DATA FORMAT

#### 2.2.1 Numeric Format

There is no thousand separator, depending on the file the “.” or “,” will be used as decimal separator.

#### 2.2.2 Date and Time Convention

Unless otherwise stated, the fields “date” are presented in a YYYYMMDD format, being YYYY the year, MM the month and DD the day. The fields “time” are presented in format HHMMSS or HHMMSSXX being HH the hour, MM the minute, SS the second and XX second hundredth. Dates and times refer to CET (Central European Time).

#### 2.2.3 Data Delivery

Information is accessible via Internet through a sFTP protocol (ssh file transfer protocol).

#### 2.2.4 File Names

Name of the files by product and type:

DESCRIPTION	FILE
Voting rights and financial instruments	BME_CNMV_DV_YYYYMMDD.zip
Relevant information. Registration Data. PDF files related to Corporate Actions	BME_CNMV_HR_PS_ID_NIF_YYYYMMDD_HHMMSS.zip BME_CNMV_HR_PS_ID_NIF_YYYYMMDD_HHMMSS.xml BME_CNMV_HR_PS_ID_NIF_YYYYMMDD_HHMMSS_attach_NN.pdf
Interim Financial Information	BME_CNMV_IFI_PS_ID_NIF_YYYYMMDD_HHMMSS.zip IFINNNNNNNNNXX.pdf IFINNNNNNNNN(N).XBRL
ISIN	BME_CNMV_ISIN_YYYYMMDD.zip
Audits	BME_CNMV_AU_YYYYMMDD.zip
List of Corporate Actions of listed companies	PRICESENSITIVE_ANNOUNCEMENT_YYYYMMDD.csv
List of corporate actions that modify or void preceding corporate actions.	EXCHANGE_NOTICES_YYYYMMDD.csv
Mab Corporate Actions	HR_MAB_YYYYMMDD.txt
<b>Issuer List</b>	<b>EMISORAS_ISIN_GLOBAL_LEI_YYYYMMDD.txt</b> <b>EMISORAS_ISIN_GLOBAL_YYYYMMDD.txt</b>
DEPOSITARIES & MANAGERS NIF	NIF_EMPGEST_YYYYMMDD.txt

### 3 File Description

#### 3.1 PRICESENSITIVE\_ANNOUNCEMENT\_YYYYMMDD.CSV

Summary list of all the corporate actions in the day that affect listed companies. The file contains the following fields:

FIELD	TYPE	MAX LENGTH	NOTE
TIPO_ENVIO	Char	1	A: Insertion of a new Corporate Action and Material Information. M: Modification of an existing Corporate Action and Material Information.
HORA_ENVIO_MENSAJE	Char	8	hh:mm:ss dissemination time
DATE	Char	19	Date/Time of issued formatted as "DD/MM/YYYY hh:mm:ss"
DATE_MODIF	Char	19	Date/Time of modified issued formatted as "DD/MM/YYYY hh:mm:ss"
PS_ID	Char	10	This identifies univocally the Price Announcement ID determining the lifecycle of the announcement.
PS_ID_MODIF	Char	10	This identifies univocally the Modified Price Announcement ID determining the lifecycle of the announcement.
TICKER	Char	12	Company Ticker Code on which the Corporate Action and Material Information is announced.
ISIN_CODE	Char	12	Company ISIN Code on which the Corporate Action and Material Information is announced.
NIF_CODE	Char	10	Company NIF Code on which the Corporate Action and Material Information is announced.
COMPANY_NAME	Char	100	Instrument Long Name on which the Corporate Action and Material Information is announced.
ISIN_CODE_ISSUER	Char	12	ISIN Code of the company announcing the Corporate Action and Material Information.
NIF_CODE_ISSUER	Char	10	NIF Code of the company announcing the Corporate Action and Material Information.
COMPANY_NAME_ISSUER	Char	100	Name of the company announcing the Corporate Action and Material Information.
SUBJECT1_CODE	Char	4	Subject code 1 associated to the Corporate Action and Material Information. CNMV Code = "<Descripcion Codigo="NNNN">" (First Subject)
SUBJECT1_DESC	Char	150	Subject code 1 description. Spanish
SUBJECT1_DESC_ENG	Char	150	Subject code 1 description. English



<b>SUBJECT2_CODE</b>	Char	4	Subject code 2 associated to the Corporate Action and Material Information. CNMV Code = “<DescripcionCodigo="NNNN">” (Second Subject)
<b>SUBJECT2_DESC</b>	Char	150	Subject code 2 description. Spanish
<b>SUBJECT2_DESC_ENG</b>	Char	150	Subject code 2 description. English
<b>SUBJECT3_CODE</b>	Char	4	Subject code 3 associated to the Corporate Action and Material Information. CNMV Code = “<DescripcionCodigo="NNNN">” (Third Subject)
<b>SUBJECT3_DESC</b>	Char	150	Subject code 3 description. Spanish
<b>SUBJECT3_DESC_ENG</b>	Char	150	Subject code 3 description. English
<b>TEXTO_HECHO_RELEV</b>	Char	2000	Text of the announcement. Spanish
<b>TEXTO_HECHO_RELEV_ENG</b>	Char	2000	Text of the announcement. English
<b>LINK1</b>	Char	250	URL 1 from where can be downloaded additional documentation on the Corporate Action and Material Information. Spanish Document.
<b>LINK1_ENG</b>	Char	250	URL 1 from where can be downloaded additional documentation on the Corporate Action and Material Information. English Document.
<b>LINK2</b>	Char	250	URL 2 from where can be downloaded additional documentation on the Corporate Action and Material Information. Spanish Document.
<b>LINK2_ENG</b>	Char	250	URL 2 from where can be downloaded additional documentation on the Corporate Action and Material Information. English Document.
<b>LINK3</b>	Char	250	URL 3 from where can be downloaded additional documentation on the Corporate Action and Material Information. Spanish Document.
<b>LINK3_ENG</b>	Char	250	URL 3 from where can be downloaded additional documentation on the Corporate Action and Material Information. English Document.

### 3.2 EXCHANGE\_NOTICES\_YYYYMMDD.CSV.

List of corporate actions in the day that affect (void or modify) preceding corporate actions of listed companies. The file contains the following fields:

FIELD	TYPE	MAX LENGTH	REQUIRED	NOTE
NOTICE_ID	Char	10	Y	This identifies univocally the Notice ID determining the lifecycle of the notice
NOTICE_TEXT	Char	2000	Y	Body Text deriving from the announcement
NOTICE_ISSUER_ISIN	Char	19	Y	ISIN Code of the company which issued the Price Sensitive Announcements (PSA)
NOTICE_LIST_ISIN_COMPANIES	Char	200	Y	List of ISIN Codes, separated with the field  , of the company influenced by the Price Sensitive Announcement. It is useful in case of holding or company quoted with different instruments: one for the ordinary shares, preference shares, and saving shares all influenced by issued put of the holding company.
NOTICE_RELEASE_DATE	Char	19	Y	ISIN Code of the company which has issued the notice formatted as "YYY-MM-DD hh:mm:ss"
NOTICE_CANCELLATION_DATE	Char	19	N	Notice cancellation date/time formatted as "YYY-MM-DD hh:mm:ss"
PS_ID	Char	10	Y	Link to the Price Announcement ID referenced by the NOTICE ID
NOTICE_STATUS	Char	1	Y	Status of the Exchange Notice. Value admitted: I=ISSUE D=DELETE
NOTICE_ISSUER_TICKER	Char	12	Y	TICKER Code of the company which issues the Price Sensitive Announcements (PSA)
NOTICE_SUBJECT1_CODE	Char	4	Y	CNMV Code = "<DescripcionCodigo="NNNN">" (First Subject)
NOTICE_SUBJECT1	Char	150	Y	Subject of the announcement. (First Subject)
NOTICE_SUBJECT1_ENG	Char	150	Y	English Subject of the announcement (See Excel file attached) (First Subject)
NOTICE_SUBJECT2_CODE	Char	4	Y	CNMV Code = "<DescripcionCodigo="NNNN">" (Second Subject)
NOTICE_SUBJECT2	Char	150	Y	Subject of the announcement. (Second Subject)
NOTICE_SUBJECT2_ENG	Char	150	Y	English Subject of the announcement (See Excel file attached) (Second Subject)
NOTICE_SUBJECT3_CODE	Char	4	Y	CNMV Code = "<DescripcionCodigo="NNNN">" (Third Subject)
NOTICE_SUBJECT3	Char	150	Y	Subject of the announcement. (Third Subject)
NOTICE_SUBJECT3_ENG	Char	150	Y	English Subject of the announcement (See Excel file attached) (Third Subject)

This file is related to the previous one, allowing to add/eliminate NOTICE\_ID to certain PS\_ID in relation to the field NOTICE\_STATUS. Separator field is "|"

### 3.3 RELEVANT INFORMATION. REGISTRATION DATA.

File(s) containing the relevant information communication made by issuers and received by the CNMV during the day in which the file was created.

The data will be available in zipped format with the name BME\_CNMV\_HR\_PS\_ID\_NIF\_YYYYMMDD\_HHMMSS.zip, where:

- PS\_ID is the ID of the corporate action,
- NIF is the Tax ID of the company,
- YYYYMMDD is the reference date of the data and
- HHMMSS is the reference time of the data.

Once unzipped, the user will find an XML file whose contents are defined in the annexes 1 and 2 of this document.

The PS\_ID allows associating each register included in the file PRICESENSITIVE\_ANNOUNCEMENT\_YYYYMMDD.CSV with its corresponding file of the corporate action.

There is one zipped file for each new corporate action receives in T for example BME\_CNMV\_HR\_00130721\_A-28027274\_20100924\_134501.zip contains a XML file with the information, for example: BME\_CNMV\_HR\_00130721\_A-28027274\_20100924\_134501.xml.

The associated pdf files are included as attachments: BME\_CNMV\_HR\_PS\_ID\_NIF\_YYYYMMDD\_HHMMSS\_attach\_XX.pdf

### 3.4 INTERIM FINANCIAL INFORMATION.

File containing all the quarterly and/or semester reports remitted to the CNMV by the companies that have securities admitted to trading in the Regulated Markets at the reference date.

The reports provided in this file are XBRL format files provided by the issuers in accordance with the IPP taxonomy and sent to the CNMV in such format.

The daily file with interim financial information is zipped with the name BME\_CNMV\_IFI\_PS\_ID\_NIF\_YYYYMMDD\_HHMMSS.zip where:

- PS\_ID is the ID of the corporate action,
- NIF is the tax ID of the company,
- YYYYMMDD is the reference date of the data and

- HHMMSS is the reference time of the data.

Once unzipped, the client has as many XBRL files as reports and their corresponding PDF format files.

The PS\_ID allows associating each register included in the PRICESENSITIVE\_ANNOUNCEMENT\_YYYYMMDD.CSV with the corresponding file of the corporate action.

A zipped file for each interim financial information received in D for example: BME\_CNMV\_IFI\_2010123384\_A-28004240\_20100927\_154101.zip with a XBRL file with the report in electronic format. In addition, a file is included in the report in PDF format together with a file for each of the attached files embedded in the XBRL file:

For example: IFI2010123384(A).XBRL, IFI2010123384CA.pdf, IFI2010123384IG.pdf, IFI2010123384IN.pdf

Being for pdf:

- IN = PDF Template with the Report Received
- IC = Complementary Information
- DI = Interim Declaration
- IF = Quarterly Financial Report
- NE = Explanatory Notes
- IG = Management Report
- IA = Auditor's Report
- CA = Summarized Annual Accounts

For xbrl:

- The initial number is the Report's CNMV entry registration number
- A=Registration
- M=Modification

- The XBRL files are adapted to the IPP taxonomy.

The Interim Financial Information ZIP file contains the different files associated to a report: in addition to the XBRL report and its PDF version, the files included in the report can be presented in any other format (doc, docx, xls,xlsx, pdf, ppt, xbrl, zip, txt...), and it is included to which part of the report they belong to.

IFINNNNNNNNNXX.ext being

- “NNNNNNNNNN” the CNMV entry registration number (included in the name of the original ZIP file).
- “XX” these two characters identify the type of information included in the file, associated to the corresponding tag of the XBRL
- “ext” is the extension of the file, which is also indicated in the XBRL.

### 3.5 AUDITS.

File(s) containing the register data of the audits of issuers that have been received in the day by the CNMV.

The data is available in a zipped format with the name BME\_CNMV\_AUYYYYMMDD.ZIP where:

- YYYYMMDD is the reference date of the data.

Once unzipped, an XML file is available with the contents described in Annex 1 and 2 of this document.

A daily zipped file referred to the audits in T-1: for example: BME\_CNMV\_AU20100322.zip which contains a XML file with the information, for example: BME\_CNMV\_AU20100322.xml

### 3.6 VOTING RIGHTS AND FINANCIAL INSTRUMENTS.

File containing the following information: final position at the date the file is generated of all the listed companies with regard to its treasury stock, voting rights and holdings of financial instruments that grant the option to acquire shares to directors, significant shareholders and executives. Communications received in the CNMV the day the file is generated in any format available for such notification.

Data is available in zipped format with the name BME\_CNMV\_DVYYYYMMDD.ZIP where: YYYYMMDD is the reference date of the data.

Once unzipped, an XML file is available with the contents described in annexes 1 and 2 of this document. One daily zipped file with the communications related to voting rights in T-1: for example: BME\_CNMV\_DV\_20100924.zip with the XML format file with the information: for example: BME\_CNMV\_DV\_20100924.xml

### 3.7 ISIN.

File containing the additions and withdrawals made during the day in the database of financial instruments of the Spanish National Agency of Securities Codification.

The data is available in zipped format with the name BME\_CNMV\_ISINYYYYMMDD.ZIP where: YYYYMMDD is the reference date of the data.

Once unzipped, a XML file is available whose contents are described in Annexes 1 and 2 of this document.

One daily zipped file related to the ISIN in T-1: for example: BME\_CNMV\_ISIN\_20100924.zip with a XML file with the information: for example: BME\_CNMV\_ISIN\_20100924.xml

### 3.8 MAB CORPORATE ACTIONS

File HR\_MAB\_YYYYMMDD.txt with the Corporate Actions, Relevant Facts and Notices of MAB companies of the last 7 days, with field separator “|”:

Nº	FIELD	SIZE	DESCRIPTION	OBSERVATIONS
1	IDENTIFICADOR	X(5)	Corporate Action Identifier.	
2	tipo	X(2)	Corporate Action Tipe	Aviso MAB / MAB Notice Aviso SICAV / SICAV Notice Aviso SOCIMI / SOCIMI Notice Aviso ECR / ECR Notice Aviso EE / EE Notice Aviso SIL / SIL Notice Hecho relevante SICAV / SICAV Corporate Action Hecho relevante ECR / ECR Corporate Action Hecho relevante EE / EE Corparte Action Hecho relevante SOCIMI / SOCIMI Corparte Action Hecho relevante SIL / SIL Corporate Action

Información Financiera (MAB) / Financial Information  
 MAB Company  
 Folleto MAB / MAB Term & Sheet

3	TITULO	X(N)	Corporate Action Tittle	
4	CLVEMIS (Clave)	X(5)	Corporate Action Issuer Code	
5	TICKER	X(5)	Corporate Action Ticker Symbol	
6	WEB	X(1)	WEB	
7	NOMBRE	X(N)	Corporate Action Issuer Name	
8	NOMBRE_FICH	X(N)	Corporate Action File Name	pdf
9	DATE_PUB	X(N)	Corporate Action Publication Date	MMM DD YYYY
10	DATO	X(N)	Description	
11	DATOS1	X(N)	Description	
12	DATOS2	X(N)	Description	
13	DATOS3	X(N)	Description	
14	DATOS4	X(N)	Description	
15	DATOS10_COD	X(N)	Description	
16	URL	X(N)	Corporate Action link to the pdf file	pdf
17	HORA	X(N)	Corporate Action Publication Time	HHMMSS
18	FECHA_PREVISTA	X(N)	Corporate Action Publication Date	
19	MERCADO	X(4)	MABX	
20	PRIORIDAD	X(n)	Priority	"Pendiente Calificar" / Pending

Auxiliar file with the Issuer Information **EMISORAS\_ISIN\_GLOBAL\_LEI\_YYYYMMDD.TXT** with the following fields:

- FECHA (Date)
- CLVEMIS (Issuer Code) (Key Field)

- TICKER (Ticker Symbol)
- ISIN (ISIN)
- NOMBRE (re de la emisora)
- COUNTRY CODE
- NIF (ISSUER NIF)
- LEI (ISSUER LEI)

Auxiliar file with the Issuer Information **EMISORAS\_ISIN\_GLOBAL\_YYYYMMDD.txt** with the following fields:

- FECHA (Date)
- CLVEMIS (Issuer Code) (Key Field)
- TICKER (Ticker Symbol)
- ISIN (ISIN)
- NOMBRE (re de la emisora)
- COUNTRY CODE

Auxiliar file with the NIF (Fiscal identifier) of managers and depositaries (NIF\_EMPGEST\_YYYYMMDD.txt) with the following fields:

- FECHA (Date)
- EMG\_DNINIF    COMPANY FISCAL IDENTIFIER (NIF)
- EMG\_NOMBRE    Long Name
- EMG\_NOMRED    Short Name



## 4 ANNEX 1

### 4.1 INTRODUCTION

The files that are included in the service contain the information that is registered every day in the CNMV:

- a) For Interim Financial Information of the Issuers, the information that having been previously received and stored, has been put at the disposal of the public in the day.
- b) For corporate actions, significant shareholdings and audits, the information that has been included in the Public Registers of the CNMV
- c) For ISIN Codes, the modifications made with a daily update.

The interim financial information of the issuers is distributed both in XBRL format as well as PDF format, the rest of the information is available in XML files with the structure that is included in the following chapters.

*Disclaimer of content from the CNMV:* the CNMV shall not be held responsible for the accuracy of public information included in its official registers, when such information has been provided by third parties in compliance with their legal obligations. The inclusion of the said information into the CNMV official registers shall exclusively imply that the information has been submitted pursuant to the applicable regulations. Consequently, the CNMV shall not be liable for any damages arising from any decision taken as a result of using any such information. The CNMV is not responsible for any inaccuracy, omission or error therein.

### 4.2 FILE DESCRIPTION

In the FTP server, there are five types of files:

- Relevant information. Registration data. File that contains the communications of relevant information made by the issuers and received in the CNMV during the day the file is generated. The data is available in a zipped format with the name BME\_CNMV\_HRYYYMMDD.ZIP where YYYMMDD is the reference date of the data. Once unzipped, a XML file is available whose contents are defined in the Annex 2, chapter 1. The associated pdf files are included as attachments: BME\_CNMV\_HR\_PS\_ID\_NIF\_YYYYMMDD\_HHMMSS\_attach\_XX.pdf
- Interim financial information. File containing all the quarterly and semester reports sent to the CNMV by the companies with securities admitted to trading in Regulated Markets at the reference date. The files available in this file are the XBRL format files, prepared by the issuers in accordance with IPP taxonomy and submitted to the CNMV in such format. The daily file with interim financial information is zipped

with the name BME\_CNMV\_IFIYYYYMMDD.ZIP where YYYYMMDD is the reference date of the data. Once unzipped, there are as many XBRL files as reports and their corresponding files in PDF format.

- Audits. File containing the registration data of the audits of the issuers received in the day by the CNMV. The data is available in a zipped format with the name BME\_CNMV\_AUYYYYMMDD.ZIP where YYYYMMDD is the reference date of the data. Once unzipped, a XML file is available whose contents are described in the Annex 2 chapter 2.
- Voting rights and financial instruments. File with the following contents:
  - Final position at the date the file is generated for all the listed companies as regards the company’s treasury stock, voting rights and holdings of financial instruments that grant the option to acquire shares to directors, significant shareholders and executives.
  - Communications received by the CNMV, at the date when the file is generated, in any model of those available for such notification:
 

The data is available in a zipped format with the name BME\_CNMV\_DVYYYYMMDD.ZIP where YYYYMMDD is the reference date of the data. Once unzipped a XML file is available whose contents are defined in Annex 2, chapter 3.
- ISIN. File containing the modifications made during the day in the database of financial instruments of the Spanish National Agency of Securities Codification. The data is available in a zipped format with the name BME\_CNMV\_ISINYYYYMMDD.ZIP where YYYYMMDD is the reference date of the data. Once unzipped, a XML file is available whose contents are described in Annex 2 section 4.

### 4.3 REGISTER DESCRIPTION

#### 4.3.1 RELEVANT INFORMATION

BME\_CNMV\_HR\_NUMERO\_ID\_YYYYMMDD\_HHMMSS.zip where

- NUMERO = number of corporate action
- ID: ID of the entity subject to the corporate action
- YYYYMMDD: date of the corporate action
- HHMMSS: time of the corporate action

TAG

FIELD NAME

OBSERVATIONS

<FechaReferencia>	File reference date	Format YYYYMMDD
<TipoMovimiento>	Modification	'REGISTRATION' 'MODIFICATION'
<EntidadObjeto> <Nif>	Tax ID number of the company reporting the information	
<EntidadObjeto> <Denominacion>	Name of the company subject to the information	
<EntidadDeclarante> <Nif>	Tax ID number of the announcing entity	
<EntidadDeclarante> <Denominacion>	Name of the announcing entity	
<RegistroOficialCnmv> <NumeroRegistroOficial>	Number of the CNMV official registration	
<RegistroOficialCnmv> <FechaRegistro>	Date official registration in CNMV	Format YYYYMMDD
<RegistroOficialCnmv> <HoraRegistro>	Time official registration in CNMV	Format HH:MM:SS
<b>Hecho relacionado. Tipo de hecho</b>	Related action. Type of action	'HR'. It is informed if the HR is related to other HR.
<b>Hecho relacionado. Nº Registro oficial del hecho con el que se relaciona.</b>	Related action. No of official register of the related action	No of official register of the related action, it is informed if the HR is related to another HR
<b>Hecho rectificado. Tipo de hecho</b>	Rectified action. Type of action	'HR'. It is informed if the HR rectifies another HR
<b>Hecho rectificado. Nº Registro oficial del hecho al que rectifica</b>	Rectified action	No of the official register of the rectified action. It is informed if the HR rectifies another HR.
<Asunto> <Descripcion Codigo="ABCD">	Code and description of the subject	See descriptive table with the different codes and subject types.
<Documentos> <Castellano> <Descripcion>	Description of the corporate action	
<Documentos>	Type of file associated to the corporate action	

<Castellano> <Fichero> <Extension>	
<Documentos> <Castellano> <Fichero> <Contenido>	Contents in base 64 of the document attached to the corporate action
<Documentos> <Ingles> <Descripcion>	Description of the corporate action (English)
<Documentos> <Ingles> <Fichero> <Extension>	Type of file associated to the corporate action (English)
<Documentos> <Ingles> <Fichero> <Contenido>	Contents in base 64 of the document attached to the corporate action (English).

The tags RectificaA and RectificadoPor are exclusive of each other and inform of the official registration number of the Corporate Action or what is being rectified.

TABLE OF CORPORATE ACTIONS SUBJECTS	
CODE	DESCRIPTION
<b>A000</b>	Issuer Information
<b>1000</b>	FINANCIAL INSTRUMENTS
<b>1010</b>	Capital increases/decreases
<b>1020</b>	Initial Public Offerings and Public Subscription
<b>1021</b>	Stock Initial Public Offerings and Public Subscription

<b>1022</b>	Initial Public Offerings and Public Subscription of instruments convertible into capital
<b>1023</b>	Initial Public Offerings and Public Subscription of fixed income and other instruments
<b>1030</b>	Stock splits and reverse splits
<b>1040</b>	Stock takeover bids
<b>1050</b>	Other securities takeover bids
<b>1060</b>	Exercise of instruments convertible into capital
<b>1070</b>	Information on dividends
<b>1080</b>	Communication of short positions
<b>1090</b>	Programmes for the buy-back and stabilization of stocks and treasury stock
<b>1100</b>	Block trades
<b>1110</b>	Liquidity and counterparty contracts
<b>1120</b>	Trading: admissions, modifications and delistings
<b>1130</b>	Trading suspensions and trading resume
<b>1140</b>	Modifications in issues and change of coupon
<b>1150</b>	Early redemption
<b>1160</b>	Credit ratings
<b>1170</b>	Securitization funds
<b>1171</b>	Securitization funds – notification of payment dates
<b>1172</b>	Securitization funds – interim financial information
<b>1173</b>	Securitization funds – modification of notarial deeds and other contracts
<b>1174</b>	Securitization funds – credit ratings
<b>1175</b>	Securitization funds – others
<b>1180</b>	Warrants, certificates and others
<b>1181</b>	Warrants, certificates and others – expiration dates and barriers

<b>1182</b>	Warrants, certificates and others – adjustments
<b>1183</b>	Warrants, certificates and others – other information
<b>1190</b>	Others on financial instruments
<b>2000</b>	BUSINESS AND FINANCIAL SITUATION
<b>2010</b>	Trades and collateral on assets
<b>2020</b>	Changes in the valuation of assets and liabilities
<b>2030</b>	Loans, bank loans and guarantees
<b>2050</b>	Changes in the business figures or client portfolios
<b>2060</b>	Changes in the investment policy, business areas and product lines
<b>2070</b>	Information on results
<b>2080</b>	I+D: results obtained, licenses, patents and trademarks
<b>2090</b>	Labor matters
<b>2100</b>	Environmental impact of the activities undertaken by the company
<b>2110</b>	Call for meetings or informative events
<b>2120</b>	Strategical plan, previsions and presentations
<b>2130</b>	Interim financial information
<b>2140</b>	Information received in Spain due to it being receiving member
<b>2150</b>	Additional information on audited annual accounts
<b>2160</b>	Resolution of law or administrative processes
<b>2170</b>	Bankruptcy situations
<b>2180</b>	Others on business and financial situation
<b>3000</b>	CORPORATE ACTIONS
<b>3010</b>	Mergers, acquisitions, spin offs and dissolutions (splits)
<b>3020</b>	Strategical agreements with third parties

<b>3030</b>	Transmission and acquisition of society stockholdings
<b>3040</b>	Others on corporate actions
<b>4000</b>	CORPORATE GOVERNANCE AND OFFICIAL CALLS
<b>4010</b>	Calls and resolutions of the General Shareholders Meetings
<b>4020</b>	Calls and resolutions of Meetings of securities holders
<b>4030</b>	Composition of the Board of Directors
<b>4040</b>	Composition of other management and control boards
<b>4050</b>	Corporate Governance Annual Report
<b>4060</b>	Extra-statutory agreements or those that imply control changes
<b>4070</b>	Remuneration systems
<b>4080</b>	Other statutory modifications
<b>4090</b>	Others on corporate governance
<b>6000</b>	INVESTMENT FUNDS TYPES AND OTHERS
<b>6130</b>	Appointment of the auditor
<b>6190</b>	Payment /capital decrease in mutual funds when this is over 20%
<b>6191</b>	Payment of all the maximum statutory capital of the Investment firm
<b>6200</b>	Leverage of the fund with third party obligations when >5%
<b>6220</b>	Substitution of Fund Manager or Depositary
<b>6221</b>	Authorization to modify the fund regulations
<b>6230</b>	Change of control in the Investment funds Manager
<b>6260</b>	Number of shareholders and net worth of foreign investment funds
<b>6300</b>	Trade suspensions and trade resume
<b>6310</b>	Revision in the credit ratings of Investment funds guarantor
<b>6450</b>	Investment funds merger

<b>6480</b>	Withdrawal/Dissolution/Liquidation of Investment funds
<b>6560</b>	Waive/reduction of management commissions of Investment funds
<b>6570</b>	Waive/reduction of depositary commissions of Investment funds
<b>6800</b>	Other corporate actions
<b>6810</b>	NAV incidences
<b>6950</b>	Delisting of Investment funds in the Stock Market
<b>6960</b>	Investment funds revocation
<b>6970</b>	Modification of essential elements in the prospectus
<b>6980</b>	Complementary information on granted guarantees and on its results
<b>6990</b>	Promotional offers of Investment funds

#### 4.3.2 AUDITS

BME\_CNMV\_AU\_YYYYMMDD.zip where:

- AU = Audit
- YYYYMMDD: file date

TAG	FIELD NAME	OBSERVATIONS
<Fecha>	Date of file reference	Format YYYYMMDD
<Entidad> <Nif>	Tax number of the audited company	
<Entidad> <Denominacion>	Name of the company	
<DenominacionAuditor>	Name of the auditor	
<NumeroRegistroOficialCNMV>	Nº Official Register of the audit in the CNMV	
<FechaRegistroOficialCNMV>	Official registration in the CNMV	Format YYYYMMDD



<TipoAuditoria>	Audit type	'individual' / 'consolidated' / 'both'
<FechaEstadosFinancieros>		Format YYYYMMDD
<OpinionAuditor>	Auditor's opinion	'Clean' / 'With qualified opinion'
<Movimiento>	Modifications	S S'NEW' / 'MODIFICATION'

### 4.3.3 ISIN

BME\_CNMV\_ISIN\_YYYYMMDD.zip where:

- ISIN = Audit
- YYYYMMDD: file date

The registers contain data on the financial instruments codified by the Spanish National Agency for the Codification of Securities. The structure of each register depends on the type of instrument, considering the following types:

- Fixed income.
- Equities.
- Rights, warrants and certificates.
- Investment funds
- Options.
- Futures.
- Currencies, underlying securities and other financial instruments with code.

#### 4.3.3.1 Fixed Income

<Rentafija>

TAG	FIELD NAME	OBSERVATIONS
<ISIN>	ISIN	
<EntidadEmisora> <Nif>	Issuer tax number	
<EntidadEmisora> <Denominacion>	Name issuer	
<Denominacion>	Security name	
<FechaAmortizacion>	Amortization date	Format YYYYMMDD
- <Tramos> - <TramoNominal> - <Detalle> <Serie>	Nominal tranche – SERIES	
- <Tramos> - <TramoNominal> - <Detalle> <Numeroinicial>	Nominal tranche – Initial No within a series	
- <Tramos> - <TramoNominal> - <Detalle> <NumeroFinal>	Nominal tranche – Final No within a series	
- <Tramos> - <TramoNominal> - <Detalle> <FechaEmision>	Nominal tranche – Final No within a series	Format YYYYMMDD
- <Tramos> - <TramoSinNominal> - <Detalle> <Serie>	Tranche without nominal – Serie	
- <Tramos> - <TramoSinNominal> - <Detalle> <Saldo>	Tranche without nominal – Amount	
- <Tramos>	Tranche without nominal – Issue date	

- <TramoSinNominal>  
 - <Detalle>  
 <FechaEmision>

<DatosInteres> <TipoInteres>	Data concerning interest – Interest rate	Variable, Fixed, Zero Coupon...
<DatosInteres> <Interes>	Data concerning interest – Interest	6 decimals
<DatosInteres> <PrimerPagoInteres>	Data concerning interest – First Interest Payment	Format YYYYMMDD
<DatosInteres> <PeriodicidadPagoInteres>	Data concerning interest – Periodicity in the Interest payment	S = Semester, .... Q = Quarterly A = Annual Formato ASB: B A S Q M W N X
<ValorNominal>	Nominal value	
Valor mínimo de negociación	Minimum trading value	
<SaldoTotal>	Total amount	
<Movimiento>	Modifications	'NEW' / 'WITHDRAWALS' / 'MODIFICATION'
<Moneda>	Currency	Following ISO 4217 standards
<CFI>	CFI	Following ISO 10962 standards

#### 4.3.3.2 Equities

<RentaVariable>

TAG	FIELD NAME	OBSERVATIONS
<ISIN>	ISIN	
<EntidadEmisora> <Nif>	Issuer tax ID number	
<EntidadEmisora> <Denominacion>	Issuer name	

<Denominacion>	Security name	
<Series> - <Detalle> <NumeroInicial>	Series – Initial N° within the series	
<Series> - <Detalle> <NumeroFinal>	Series – Final N° within the series	
<Series> - <Detalle> <FechaEmision>	Issue date	Format YYYYMMDD
<ValorNominal>	Nominal value	2 decimals
<PortadorNominativas>	Bearer / nominative	'Bearer' / 'Nominative'
<Movimiento>	Modification	'ALTA' / 'BAJA' / 'MODIFICACION'
<Moneda>	Currency	Following ISO 4217 standards
<CFI>	CFI	Following ISO 10962 standards

#### 4.3.3.3 Rights, Warrants, Certificates

<DerechosWarrantsCertificados>

TAG	FIELD NAME	OBSERVATIONS
<ISIN>	ISIN	
<EntidadEmisora> <Nif>	Issuer tax ID number	
<EntidadEmisora> <Denominacion>	Issuer name	
<Denominacion>	Security name	
<NumeroInicial>	Initial N°	

<NumeroFinal>	Final N°	
<FechasInicialFinal> <WarrantsCertificados> <Derechos> <FechaEmision>	Issue date (warrants, certificates) / Initial period date (rights)	Format YYYYMMDD
<FechasInicialFinal> <WarrantsCertificados> <Derechos> <FechaVencimiento>	Expiration date warrants, certificates / End period date (rights)	Format YYYYMMDD
<Movimiento>	Modification	'ALTA' / 'BAJA' / 'MODIFICACION'
<Moneda>	Currency	Following ISO 4217 standards
<CFI>	CFI	Following ISO 10962 standards

#### 4.3.3.4 FI, FIL, FCR, FII (Funds)

<FiFilFcrFii>

TAG	FIELD NAME	OBSERVATIONS
<ISIN>	ISIN fund holdings	
<DenominacionFondo>	Fund name	
<FechaInscripcion>	Inscription date	Format YYYYMMDD
<Movimiento>	Modification	'ALTA' / 'BAJA' / 'MODIFICACION'
<CFI>	CFI	Following ISO 10962 standards

#### 4.3.3.5 Options

<Opciones>

TAG	FIELD NAME	OBSERVATIONS
-----	------------	--------------

<ISIN>		
<Denominacion>		
<FechaVencimiento>		Format YYYYMMDD
<TipoOpcion>		'C' (Call) / 'P' (Put)
<ISINSubyacente>		
<DenominacionSubyacente>		
<PrecioEjercicio>		2 decimals
<CodigoContrato>		Contract code of the market
<Movimiento>	Modification	'ALTA' / 'BAJA' / 'MODIFICACION'
<Moneda>	Currency	Following ISO 4217 standard
<CFI>	CFI	Following ISO 10962 standard

#### 4.3.3.6 Futures

<Futuros>

TAG	FIELD NAME	OBSERVATIONS
<ISIN>	Future's ISIN	
<Denominacion>	Description	
<FechaVencimiento>	Expiration date	
<ISINSubyacente>	Underlying security's ISIN	
<DenominacionSubyacente>	Name of the underlying security	
<CodigoContrato>	Contract Code	Market contract code
<Movimiento>	Modification	'ALTA' / 'BAJA' / 'MODIFICACION'
<Moneda>	Currency	Following ISO 4217 standards

<CFI>

CFI

Following ISO 10962 standards

#### 4.3.3.7 Currency, Underlying Security and Others

<MonedasSubyacentesOtro>

TAG	FIELD NAME	OBSERVATION
<ISIN>	ISIN of the currency, underlying security, and other financial Instruments with code	
<Denominacion>	Description	
<Movimiento>	Modification	'ALTA' / 'BAJA' / 'MODIFICACION'
<CFI>	CFI	Following ISO 10962 standards

#### 4.3.4 VOTING RIGHTS AND FINANCIAL INSTRUMENTS

Voting rights and financial instruments. This file contains two types of information:

Final position of treasury stock and directors and significant shareholders in the listed companies at the date of the file creation. In the final position a distinction is made between voting rights and the financial instruments that grant the option to acquire shares.

Communications received by the CNMV, at the date the file is created, following any notification model:

The communication register is made up of a main body and an annex that depends on the model used in the communication:

- Annex I – Notification model for voting rights attributable to shares in listed companies for persons obliged that do not hold the position of Director of the issuer
- Annex II – Notification model for financial instruments linked to shares of listed companies for persons obliged that do not hold the position of Director of the issuer.
- Annex III – Notification model for voting rights attributable to shares and other transactions on listed companies' shares. Model for Directors.

- Annex IV – Notification model for transactions on financial instruments linked to shares of listed companies. Model for Directors.
- Annex V – Notification model for transactions on shares and other financial instruments linked to shares of listed companies. Model for executives, not directors.
- Annex VI – Notification model for transactions made with own shares.

#### 4.3.4.1 FINAL POSITION

Final position of treasury stock and directors and significant shareholders of all the listed companies as from the date the file is created. In the final position a distinction is made between voting rights and financial instruments that grant the option to acquire shares.

<PosicionFinal>

TAGS	FIELD NAME	OBSERVATIONS
<FechaDatos>	Reference day of the file	Format YYYYMMDD
<Sociedad> <DatosIdentificativos>	<Nif> <Denominacion>	
<Sociedad> <DetalleDerechosVoto_IF> <PosicionFinalDerechosVoto_IF> <SujetoObligado> <DatosIdentificativos>	<Nif> <Denominacion>	Obliged person. Tax ID number Issuer. Name Obliged person. Name Only if the person is not a physical person
<Sociedad> <DetalleDerechosVoto_IF> <PosicionFinalDerechosVoto_IF> <SujetoObligado>	<PerteneceAlConsejo>	Obliged person. Belonging to the Board. 'SI' / 'NO'
<Sociedad> <DetalleDerechosVoto_IF> <PosicionFinalDerechosVoto_IF>	<NumeroRegistroEntrada> <FechaRegistroEntrada>	Registration number of the voting rights communication. Registration date of the voting rights communication. Format YYYYMMDD



<b>&lt;PosicionFinalDV&gt;</b>	<b>&lt;TotalDerechosVoto&gt;</b>	Total voting rights of the issuer	
	<b>&lt;PorcentajeDerechosVotoDirectos&gt;</b>	Percentage direct voting rights.	
	<b>&lt;PorcentajeDerechosVotoIndirectos&gt;</b>	Percentage indirect voting rights.	
	<b>&lt;PorcentajeDerechosVotoTotal&gt;</b>	Total voting rights percentage.	
<b>&lt;Sociedad&gt; Instrumentos financieros</b>		Registration number of the financial instruments communication.	
		Registration date of the financial instruments communication.	Formato YYYYMMDD
		Percentage buy. Financial instruments.	
		Percentage transfer. Financial Instruments.	
<b>&lt;Sociedad&gt; &lt;DetalleAutocartera&gt;</b>	<b>&lt;NumeroRegistroEntrada&gt;</b>	Registration number of the Voting rights communication.	
	<b>&lt;FechaRegistroEntrada&gt;</b>	Registration date of the voting rights communications.	Format YYYYMMDD
	<b>&lt;TotalDerechosVoto&gt;</b>	Total issuer voting rights	
	<b>&lt;PorcentajeDerechosVotoDirectos&gt;</b>	Percentage direct voting rights.	
	<b>&lt;PorcentajeDerechosVotoIndirectos&gt;</b>	Percentage indirect voting rights.	
	<b>&lt;PorcentajeDerechosVotoTotal&gt;</b>	Total percentage voting rights.	

#### 4.3.4.2 COMMUNICATIONS

Detail of the voting rights or financial instruments communications <ComunicacionesRecibidas>

TAGS	FIELD NAME	OBSERVATIONS
<b>&lt;FechaDatos&gt;</b>	File reference date	Format YYYYMMDD
<b>&lt;NumeroRegistroEntrada&gt;</b>	CNMV Registration Number	
<b>&lt;Modelo&gt;</b>	Annex type	I, II, III, IV, V, VI
<b>&lt;SociedadEmisora&gt;</b>	<b>&lt;/Nif&gt;</b>	Issuer Tax ID number

	<Denominacion>	Issuer. Name	
<SujetoObligado>	<Nif>	Obligated person. Tax ID number	Only if the obliged person is not a physical person
	<Denominacion>	Obligated person. Name	
<TotalDerechosVoto>		Total issuer voting rights	
		Subject of the communication. Description or point.	
		Date that leads to the communication. Only applicable to annexes I and II. In the rest, the transaction dates.	Format YYYYMMDD
<DetalleAnexo>	<DetalleAnexo1>	Detail corresponding Annex	Depending on the field value one of the following registration types will appear: Detail annex I Detail annex II Detail annex III Detail annex IV Detail annex V Detail annex VI
	<DetalleAnexo2>		
	<DetalleAnexo3>		
	<DetalleAnexo4>		
	<DetalleAnexo5>		
	<DetalleAnexo6>		

4.3.4.2.1 Detail Annex I

FIELD NAME	OBSERVATIONS
Voting rights final holdings	
Indirect details	

4.3.4.2.2 Detail Annex II

FIELD NAME	OBSERVATIONS
Voting rights final holdings	
Direct details	

4.3.4.2.3 Detail Annex III

FIELD NAME	OBSERVATIONS
Transactions	
Voting rights final holdings	
Indirect details	

4.3.4.2.4 Detail Annex IV

FIELD NAME	OBSERVATIONS
Transactions	
Final voting rights holdings in case of exercise	

4.3.4.2.5 Detail Annex V

FIELD NAME	OBSERVATIONS
Transactions	

4.3.4.2.6 Detail Annex VI

FIELD NAME	OBSERVATIONS
Transactions	
Final holdings voting rights	
Indirect details	

4.3.4.2.7 Final holdings. Voting rights (for annexes I, III, VI)

FIELD NAME	OBSERVATIONS
ISIN	
No of direct voting rights	
No of indirect voting rights	
Total voting rights	
Percentage direct voting rights	
Percentage indirect voting rights	
Percentage total voting rights	

- <PosesionFinalDV>

- <Detalle>

<ISIN>ES014209317</ISIN>

<DerechosVotoDirectos>52470</DerechosVotoDirectos>

<DerechosVotoIndirectos>0</DerechosVotoIndirectos>

<TotalDerechosVoto>52470</TotalDerechosVoto>

<PorcentajeDerechosVotoDirectos>0.053</PorcentajeDerechosVotoDirectos>

<PorcentajeDerechosVotoIndirectos>0.000</PorcentajeDerechosVotoIndirectos>

<PorcentajeTotalDerechosVoto>0.053</PorcentajeTotalDerechosVoto>  
</Detalle>

4.3.4.2.8 Final holdings. Financial Instruments (for annex IV)

FIELD NAME	OBSERVATIONS
Financial instrument description	
Settlement by physical delivery	'SI' / 'NO'
Voting rights attributable to shares to acquire in case of exercise.	
% of voting rights attributable to shares to acquire in case of exercise	
Voting rights attributable to shares to be transmitted in case of exercise	
% of voting rights attributable to shares to be transmitted in case of exercise	

4.3.4.2.9 Final Holdings. Financial Instruments (for annex II)

FIELD NAME	OBSERVATIONS
Financial instrument description	
Last expiration date or expiration of the financial instrument	Format YYYYMMDD
Beginning of Exercise/convertibility date or period	Format YYYYMMDD
End of Exercise/convertibility date or period	Format YYYYMMDD
Position in No of voting rights in case of exercise	
Position in percentage of voting rights	

4.3.4.2.10 Detalle indirectos (para anexos I, II, III, VI)

FIELD NAME	OBSERVATIONS
Tax ID number holder	Only if the person is not a physical person
Holder Name	
Percentage	

= <Indirectos>

= <Detalle>

= <Titular>

<Denominacion>GESTION DE NEGOCIOS ARGOS</Denominacion>

</Titular>

<Porcentaje\_Acciones>4.100</Porcentaje\_Acciones>

</Detalle>

= <Detalle>

= <Titular>

<Denominacion>METAINVERSION</Denominacion>

</Titular>

<Porcentaje\_Acciones>4.067</Porcentaje\_Acciones>

</Detalle>

= <Detalle>

4.3.4.2.11 Detalle indirectos (para anexos I, II, III, VI)

FIELD NAME	OBSERVATIONS
Tax ID number holder	Only if the person is not a physical person
Holder Name	
Percentage	

## 4.3.4.2.12 Transactions (Annex III)

FIELD NAME	OBSERVATIONS
Transaction date	Format YYYYMMDD
Transaction type	'Adquisición' / 'Transmisión'
ISIN	
Nature of the transaction	
Nº of shares / voting rights. Direct	
Nº of shares / voting rights. Indirect	
Price	
Market	
Physical delivery	'SI' / 'NO'
Voting rights attributable to shares to be transmitted or acquired. In the case that the value in 0 this implies that the transactions made do not belong or are not controlled by the obliged person.	

- <DetalleAnexo3>
- <Operaciones>
- <Detalle>

```

<Fecha>20110922</Fecha>
<TipoTransaccion>Adquisicion</TipoTransaccion>
<ISIN>ES0116494016</ISIN>
<NaturalezaOperacion>ADQUISICION</NaturalezaOperacion>
<AccionesDirectas>0</AccionesDirectas>
<AccionesIndirectas>47000</AccionesIndirectas>
<Precio>1.17</Precio>
<Mercado>MB</Mercado>
<DerechosVoto>47000</DerechosVoto>
</Detalle>
    
```

#### 4.3.4.2.13 Transactions (for Annex IV)

FIELD NAME	OBSERVATIONS
Transaction date	Format YYYYMMDD
Financial Instrument description	
Nature of the Transaction	
Nº of shares	
Last date (exercise or convertibility)	Format YYYYMMDD
Initial date (exercise or convertibility)	Format YYYYMMDD
Final date (exercise or convertibility)	Format YYYYMMDD
Premium	
Price	
Market	



<b>Physical delivery</b>	'SI' / 'NO'
<b>Voting rights attributable to shares to be transmitted or acquired. In the case that the value in 0 this implies that the transactions made do not belong or are not controlled by the obliged person.</b>	
<b>Percentage previous concept on the voting rights total.</b>	

4.3.4.2.14 Transactions (for Annex V)

FIELD NAME	OBSERVATIONS
<b>Transactions on shares or financial instruments</b>	'OPERACIONES CON ACCIONES' / 'OPERACIONES CON INSTRUMENTOS FINANCIEROS'
<b>Nature</b>	
<b>Date</b>	Format YYYYMMDD
<b>Market</b>	
<b>Volume</b>	
<b>Unit price</b>	

4.3.4.2.15 Transactions (for Annex VI)

FIELD NAME	OBSERVATIONS
<b>Transaction date</b>	Format YYYYMMDD
<b>Acquisition/Transmmission</b>	'Adquisicion' / 'Transmisión'
<b>Class /ISIN</b>	
<b>Nº of direct shares</b>	
<b>Direct shares price</b>	

**Nº of indirect shares**

---

**Indirect shares price**

---

**Nº of direct voting rights**

---

**Nº of indirect voting rights**

---

**Total voting rights**

---

**Percentage of indirect voting rights**

---

**Percentage of indirect voting rights**

---

**Total percentage of voting rights**

---

- <DetalleAnexo6>

- <Operaciones>

- <Detalle>

<Fecha>20110602</Fecha>

<TipoTransaccion>Adquisicion</TipoTransaccion>

<ISIN>ES014209317</ISIN>

<AccionesDirectas>21577</AccionesDirectas>

<PrecioDirectas>25.06</PrecioDirectas>

<AccionesIndirectas>0</AccionesIndirectas>

<PrecioIndirectas>0.00</PrecioIndirectas>

<DerechosVotoDirectos>21577</DerechosVotoDirectos>

<DerechosVotoIndirectos>0</DerechosVotoIndirectos>

<TotalDerechosVoto>21577</TotalDerechosVoto>

<PorcentajeDerechosVotoDirectos>0.022</PorcentajeDerechosVotoDirectos>

<PorcentajeDerechosVotoIndirectos>0.000</PorcentajeDerechosVotoIndirectos>

<PorcentajeTotalDerechosVoto>0.022</PorcentajeTotalDerechosVoto>

</Detalle>

## 5 Annex 2. Definition of the XML Files Schemes

### 5.1 RELEVANT INFORMATION FILES

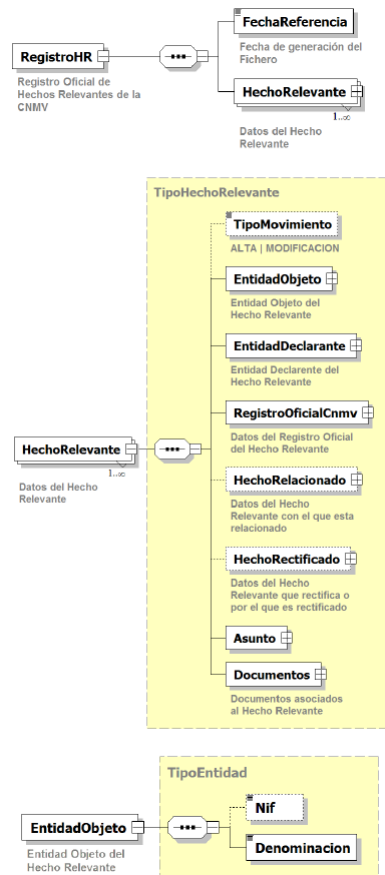

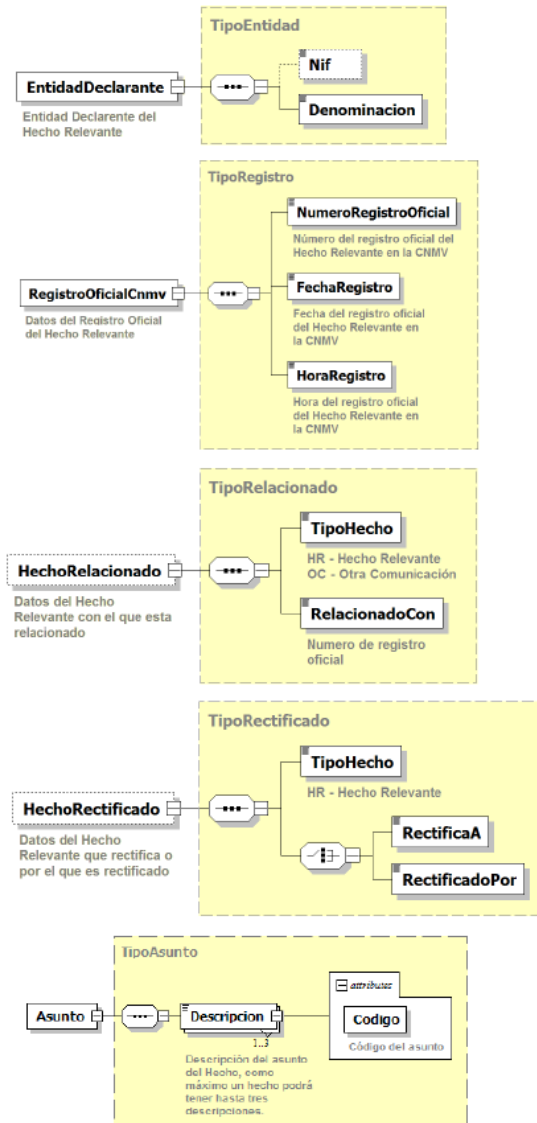

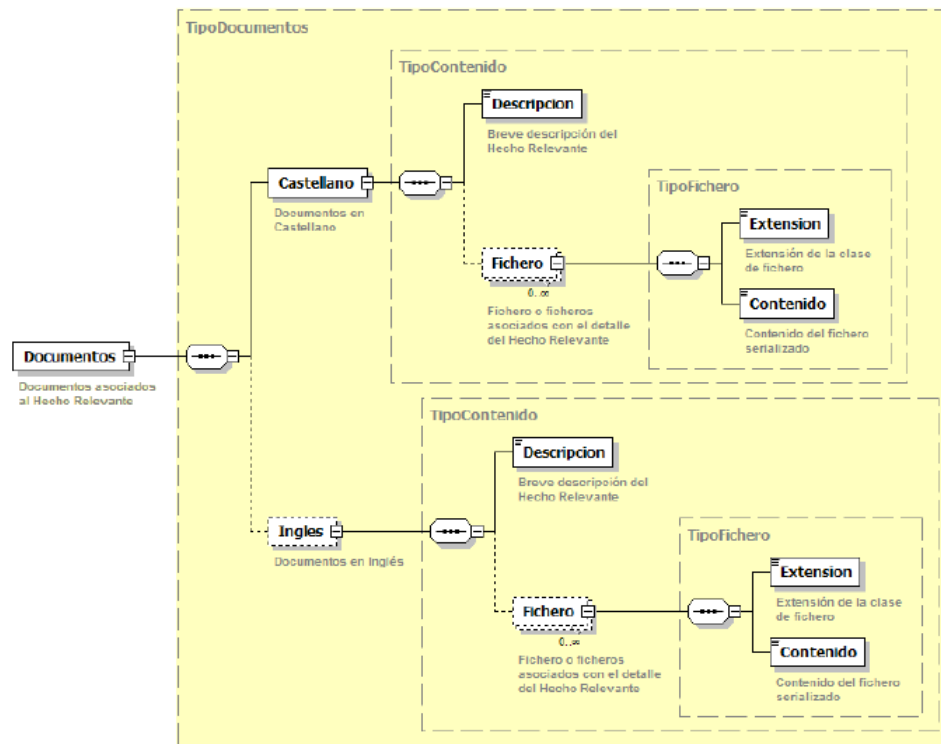

5.2 AUDIT FILES

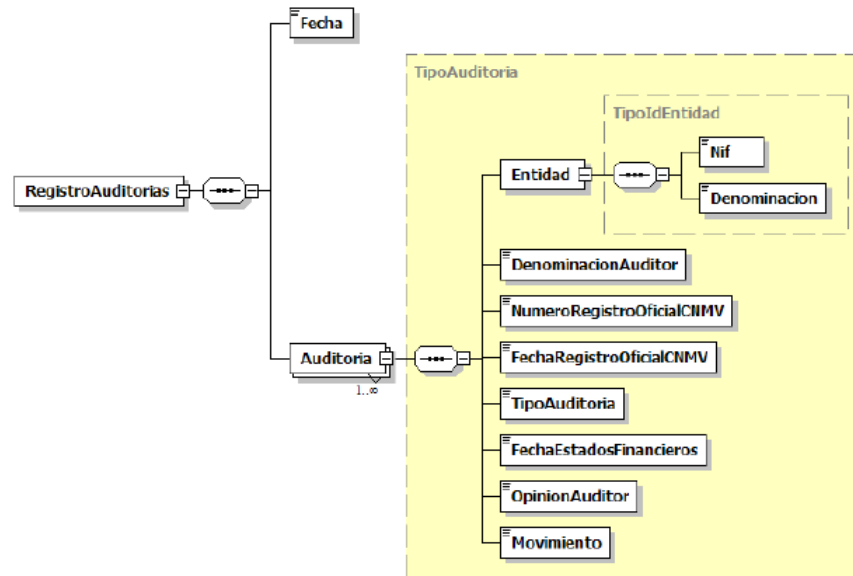

5.3 VOTING RIGHTS AND FINANCIAL INSTRUMENTS FILES

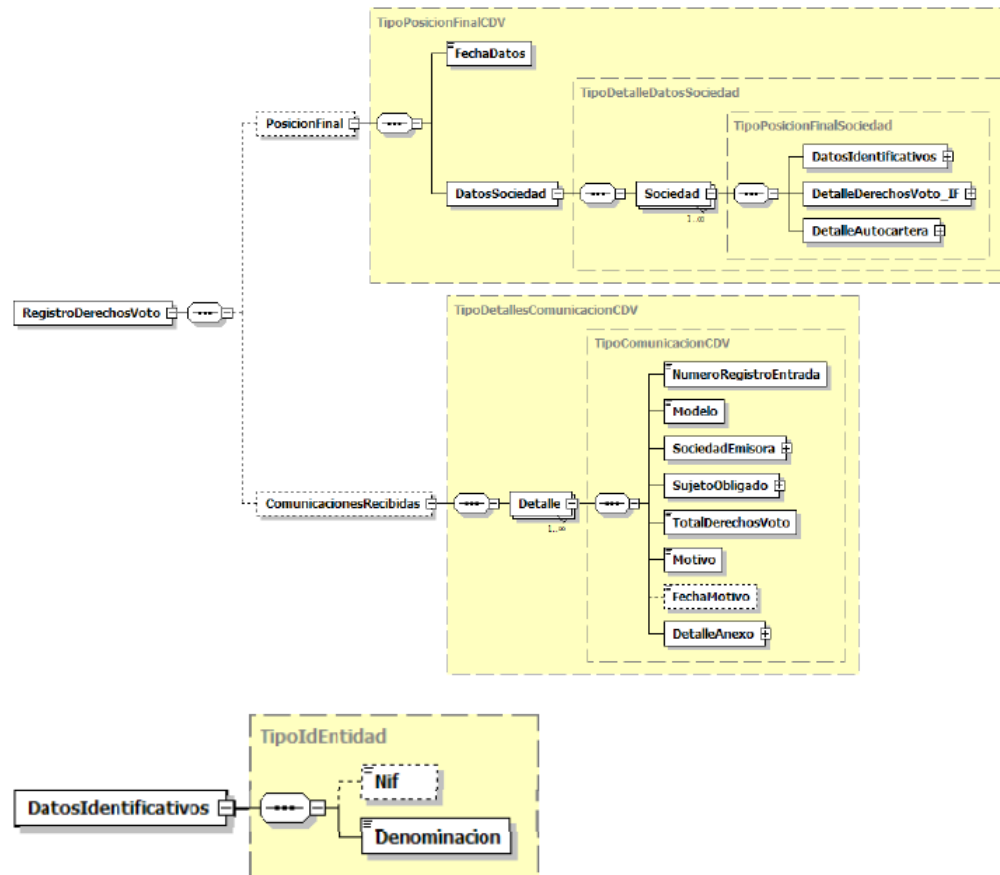



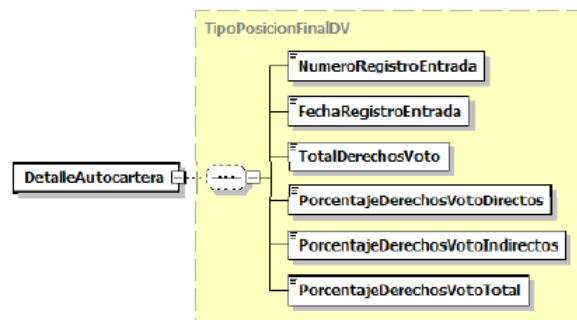
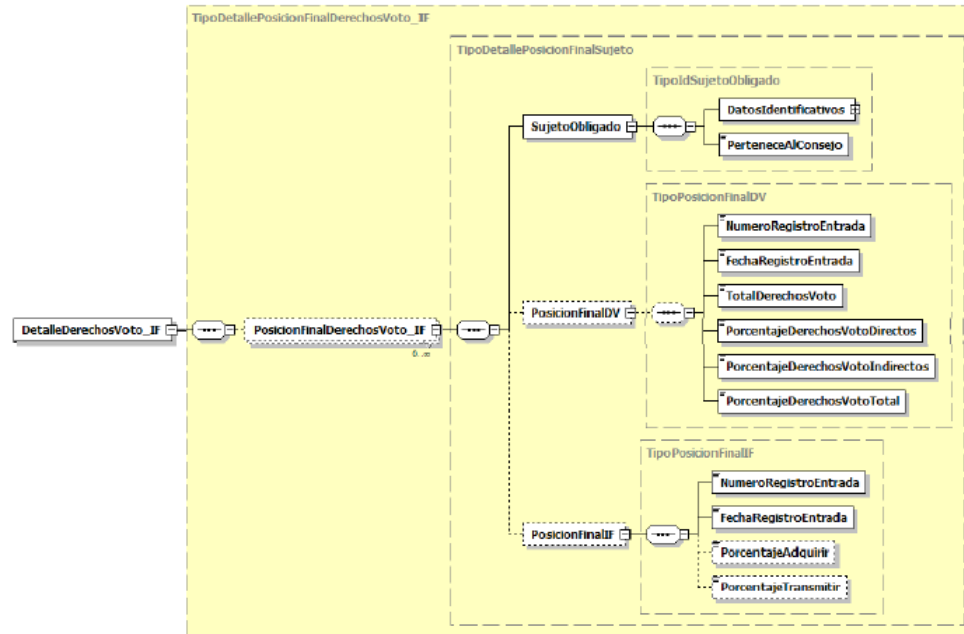

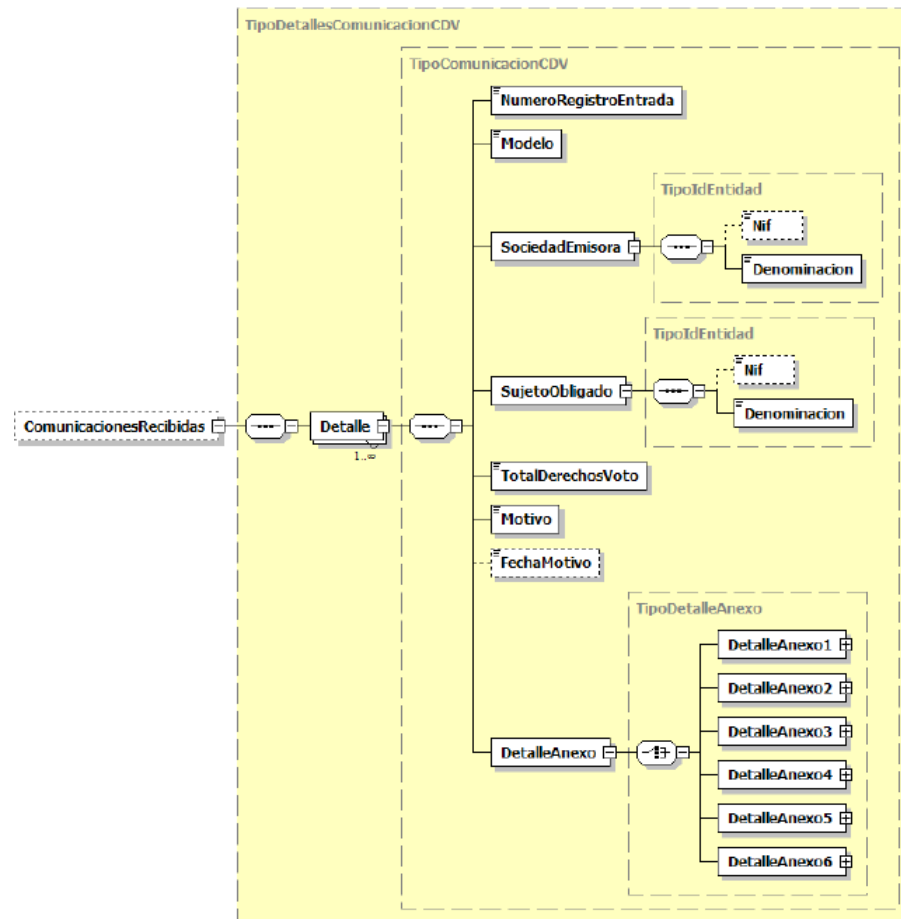

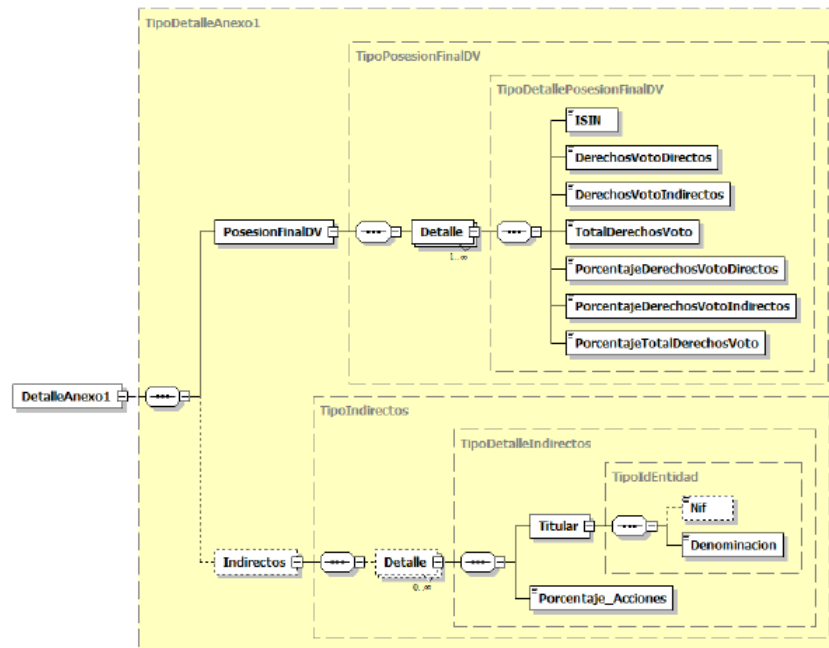

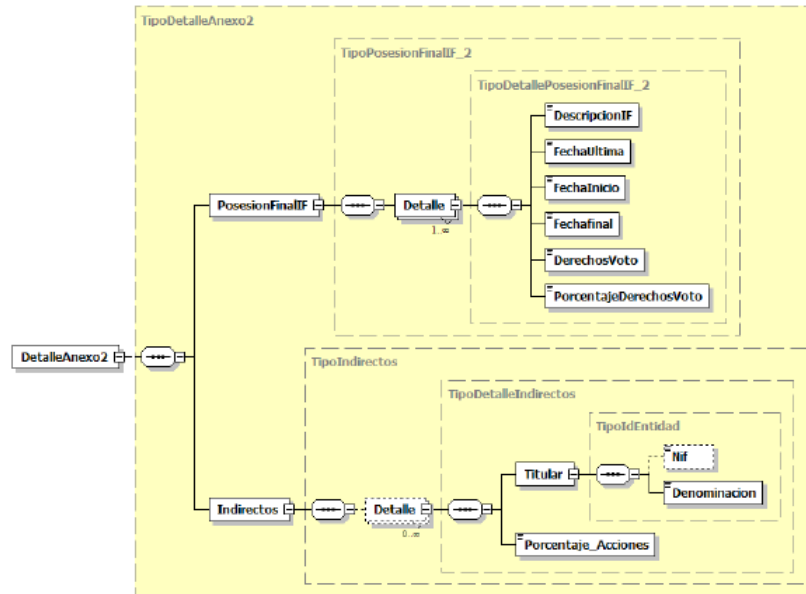

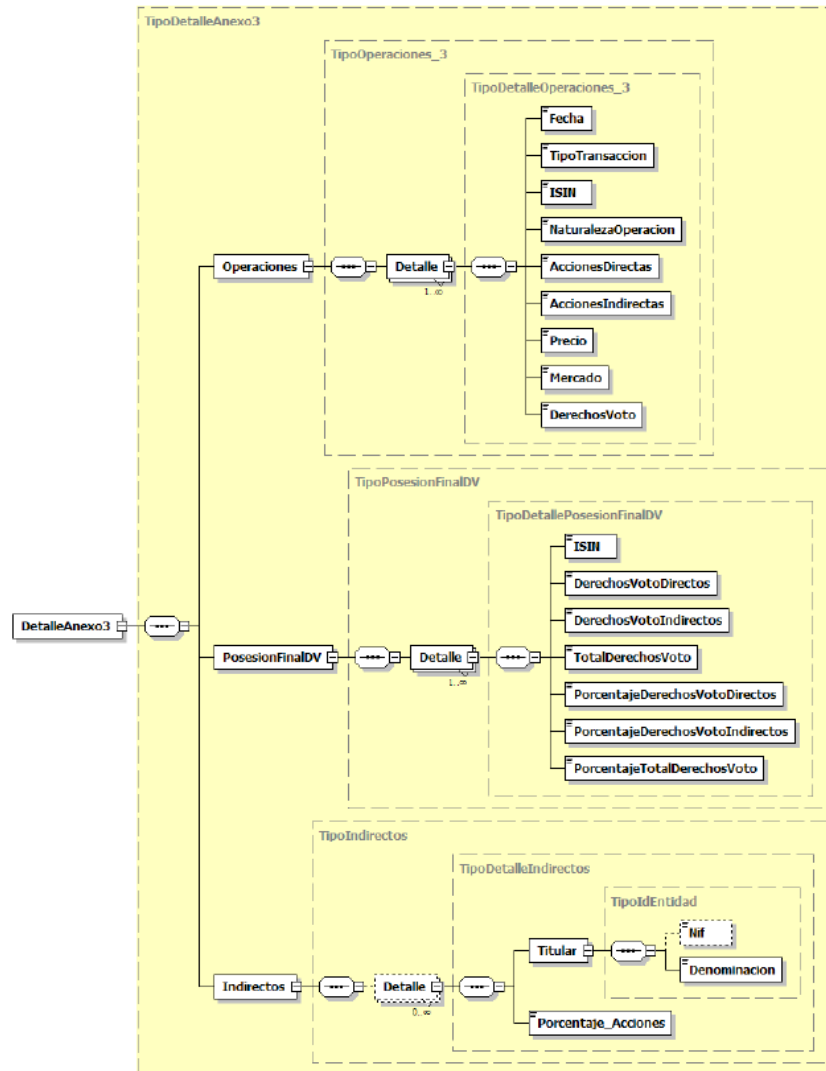

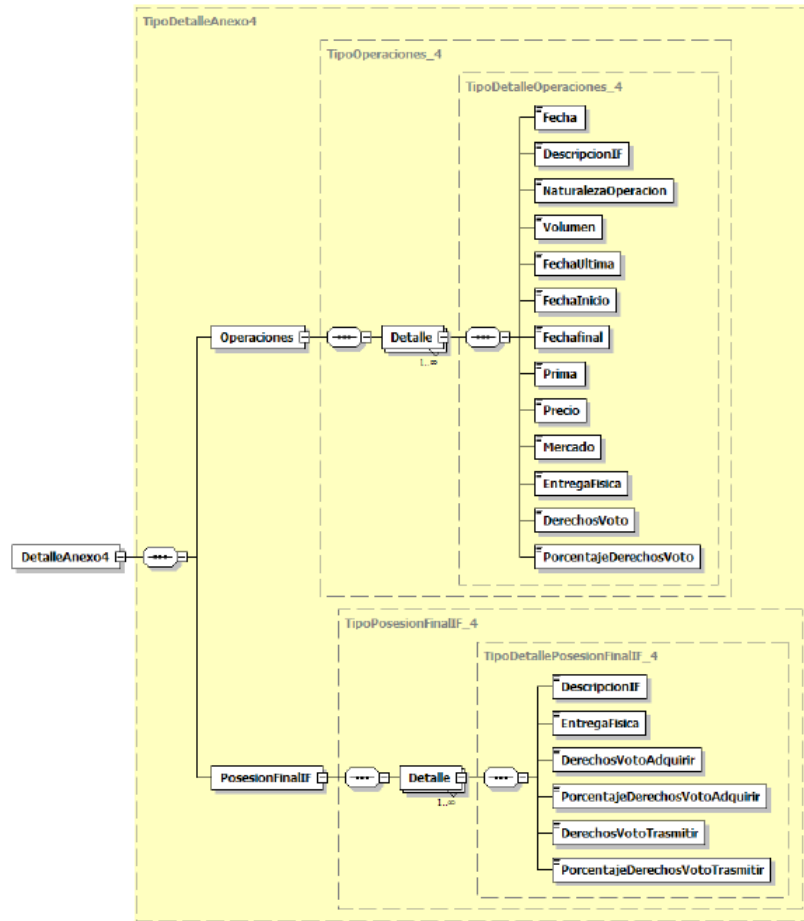

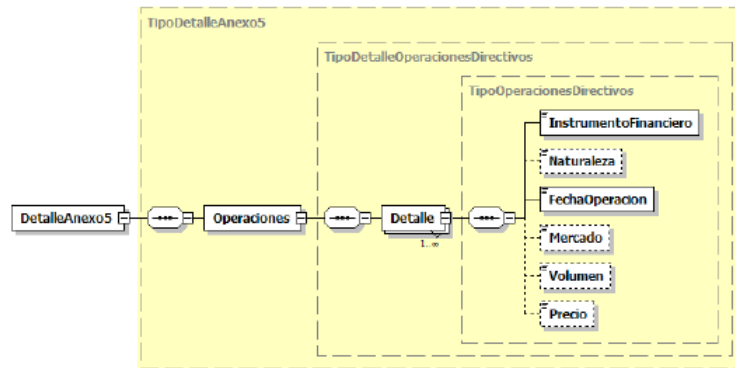

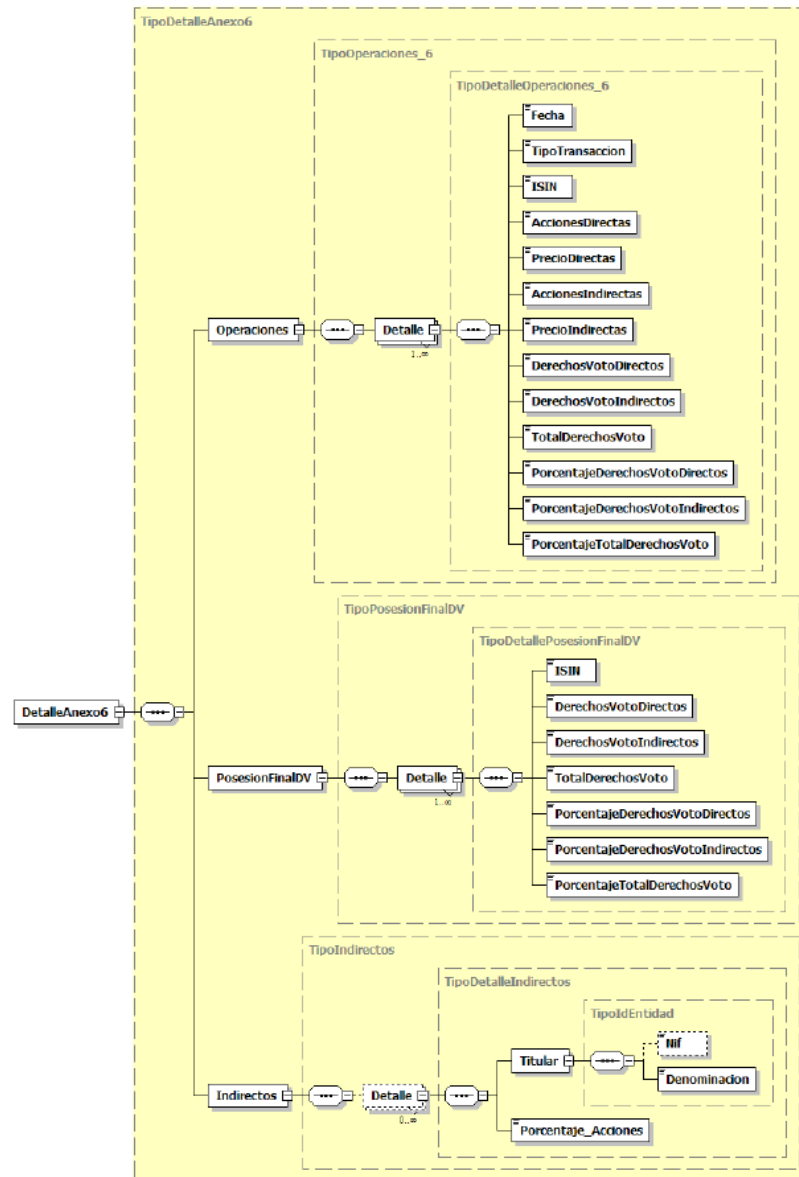



5.4 ISIN FILES

